

SCA 2026
Supercomputing Asia
Gathering the Best of HPC in Asia

**HPC
Asia
2026**

SCA/HPCAsia 2026

Everything with HPC-AI, Cloud, QC and Future Society

Date

January 26-29, 2026

Venue

Osaka International Convention Center
(Osaka, Japan)

Sponsorship Prospectus

◇Host Organization
SupercomputingAsia 2026
The International Conference on High Performance Computing in Asia-Pacific Region 2026

◇Sponsorship Secretariat of SCA/HPCAsia 2026
c/o Convention Linkage, Inc.
11F PIAS TOWER, 3-19-3 Toyosaki, Kita-ku, Osaka-city, Osaka 531-0072, Japan
E-mail: sponsor-sca_hpcasia_2026@c-linkage.co.jp Tel: +81-6-6377-2188

<https://www.sca-hpcasia2026.jp/>



as of September 26, 2025

SCA/HPCAsia 2026

The SupercomputingAsia (SCA) is a major annual international HPC event in Asia established in 2018. The conference is co-organized by HPC centers from Australia, Japan, Singapore, and Thailand, and has become a key networking and collaboration platform for the regional and global supercomputing community, for both the public and private sectors.

The International Conference on High Performance Computing in Asia-Pacific Region (HPCAsia) is an international conference series for the Asia Pacific region on HPC technologies, that promote exchange of ideas, research results, and case studies related to all issues of high-performance computing.

In Osaka, SCA and HPCAsia cooperate again and jointly host SCA/HPCAsia 2026.

The collaborative and collective strength from two of Asia's established conferences creates synergy among key HPC researchers, academics, technology specialists and industry leaders from across the region and beyond. Under the title "Everything with HPC - AI, Cloud, QC and the Future Society," AI, cloud and QC communities along with supercomputing community are invited to get together to create the future.

Opportunities and Benefits for Exhibitors:

- Showcase your cutting-edge technology in the field of supercomputing, AI, big data, cloud computing, quantum computing and semiconductors.
- Reach new domestic and international customers.
- Raise company profile through networking and sponsorship opportunities.
- Build business relationships with major global companies and leading researchers.
- Attract global talent from Asia and other countries.

SCA/HPCAsia 2026 Program (Tentative)

	January 26 (Mon)	January 27 (Tue)	January 28 (Wed)	January 29 (Thu)
AM	Workshops Tutorials	Opening Session Keynote Speech Industry Session Research Session Invited Session	Keynote Speech Industry Session Research Session Invited Session	Keynote Speech Closing Session Industry Session Research Session Invited Session
Noon	Lunch	Lunch	Lunch	Lunch
PM	Workshops Tutorials	Industry Session Research Session Invited Session	Industry Session Research Session Invited Session	Industry Session Research Session Invited Session Workshops Tutorials
Evening	Reception (invitation only)	Banquet		
All Day			Exhibition	

*Excursion to R-CCS : January 30 (Fri)

SPONSORSHIP PACKAGES

	DIAMOND JPY 100,000,000	PLATINUM JPY 5,000,000	GOLD JPY 3,000,000	SILVER ^{*2} JPY 1,000,000	BRONZE ^{*2} JPY 500,000	START-UP ^{*1} JPY 200,000
EXHIBITION SPACE						
Raw space for sponsor build-up Optional items per one (1) space: •Back panel •One (1) display table and two (2) chairs *Start-up Package (per one (1) space) includes: •Back panel (H2.7m x W0.9m) •One (1) display table	1 4m x 8m	1 4m x 4m	1 2m x 4m	1 2m x 3m	1 2m x 2m	1 1m x 1m *Built-in booth
LUNCH SPEAKER SESSIONS						
One(1) 60-minute speaking slot during lunch time. Sponsors are responsible for the program including lunch arrangement.	✓	✓	✗	✗	✗	✗
EXHIBITOR'S SUITE						
Sponsors can apply for the exhibitor's suite. Diamond, Platinum sponsors will receive priority in the application process.	✓	✓	✓	✗	✗	✗
COMPLIMENTARY PASSES						
Conference Passes Includes onsite access to all conference sessions and networking events (standard price: JPY 95,000).	20	10	6	2	1	1
Exhibition Passes Includes access to the exhibition area only (standard price: JPY 20,000).	20	10	6	2	1	1
LOGO EXPOSURE						
•Company logo on the SCA/HPCAsia 2026 official website •Company logo/name in general conference materials (e.g. program, proceedings, handouts)	✓	✓	✓	✓	✓	✓
PROMOTIONAL MATERIALS						
One (1) corporate brochure (maximum size: A4) and one (1) corporate gift inserted into the conference bag.	✓	✓	✓	✓	✓	✓
ATTENDEE CONTACT LIST(opt-in)						
The contact information of the registered attendee (name, company name, job title, email address, country).	✓	✓	✓	✗	✗	✗
EXHIBITORS FORUM						
15-minute onsite speaking opportunity in the exhibition hall.	2	1	1	1	✗	✗

*1 Applicable to companies established after January 2016.

*2 Japanese universities and research institutions will receive a discount when applying for the SILVER or BRONZE package. The discounted price will be informed separately. Note: Consumption tax is included in all prices.

OTHER CUSTOMIZED SPONSORSHIP STREAMS

Customized packages can be designed to suit your specific requirements or as an addition to standard sponsorship options.

Lanyards: JPY 500,000

Add your company name or logo to the SCA/HP Asia 2026 conference lanyard.

sold-out

Conference Bag: JPY 400,000 – 600,000

Add your company name or logo to the SCA/HP Asia 2026 conference bags. The cost varies depending on the number of sponsors.

sold-out

Beverage Station: JPY 600,000

Company name displayed at the beverage station.

Opportunity to supply following branded items at the beverage station.

Water bottles (500 bottles) : JPY 500,000

Paper cups (3,000 cups) : JPY 400,000

sold-out

Floor Map and Exhibit Locator Floorplan: JPY 2,500,000

Will be handed out to participants on site. The cost can be shared with multiple companies.

Signs and Graphics : 800,000 – 2,000,000

You can design your company's advertisements.

1. Standing Sign Board (1F) (W900 × H3000) : JPY 800,000 [Signboard Location](#)
2. Standing Sign Board (10F) (W4500 × H2400) : JPY 600,000 [Signboard Location](#)
3. Elevator Door Wrap : JPY 2,000,000 (6 units/floor) or JPY 1,000,000 (3 units/floor) [Signboard Location](#)

sold-out

*Kindly refer to the respective links for each location.

Note: Consumption tax is included in all prices.

Please contact sponsor-sca_hpcasia_2026@c-linkage.co.jp for inquiries.

OTHER CUSTOMIZED SPONSORSHIP STREAMS

Reception Dinner Sponsor on January 26: JPY 4,000,000 – 5,000,000

Opportunity to deliver opening remarks and display your company name at the reception venue. The cost may vary depending on the venue, the number of dishes to be served and the content. The cost can be shared between multiple companies.

Banquet Dinner Sponsor on January 27: JPY 10,000,000

Opportunity to deliver opening remarks and display your company name at the banquet venue. The cost may vary depending on the number of dishes served and their content. The cost can be shared among multiple companies.

Lunch Sponsor (Exhibition hall) : 1,000,000 – 3,500,000

Company name displayed in the lunch area and announcement by the conference organizer.

1. January 26: **JPY 1,000,000**. Bento box served to the Workshop/Tutorial participants.
2. January 27, 28, 29: **JPY 3,500,000** per day/sponsor. Buffet provided in the exhibition area.

Morning/Afternoon Tea Break Sponsorship (Exhibition Hall) : JPY 2,000,000 / day

Company name displayed and/or opportunity to supply branded items (e.g., cups, napkins)

Paper cups (1,000 cups): **JPY 200,000**

Napkins (1,000 napkins): **JPY 100,000**

Japanese Tea Ceremony Stand Sponsorship: JPY 800,000 / 2 hours

Opportunity to offer Japanese tea ceremony experience with matcha and seasonal sweets. Company name displayed at the Japanese tea ceremony space and announcement by the conference organizer.

Food Stand Sponsorship (Banquet) : JPY 500,000 – 700,000

Company name displayed at the food stand during the banquet.

Food stand include sushi, udon, takoyaki, tempura, oden, etc. Costs varies depending on the type of food stand and the number of items served.

Excursion Sponsorship (Kobe and Fugaku Tour) : JPY 400,000

Opportunity to provide a bus tour of the SCKE Center for Computational Science and Kobe City. Other promotional materials and activities can be arranged upon request for an extra fees.

sold-out

Note: Consumption tax is included in all prices.

Please contact sponsor-sca_hpcasia_2026@c-linkage.co.jp for inquiries.

SPONSORSHIP REGISTRATION PROCESS

Schedule

Sponsorship / Other customized sponsorship stream registration deadline	August 22 (Fri), 2025
Submission of <ul style="list-style-type: none"> Booth plan request: Raw space or Basic booth LUNCH SPEAKER SESSIONS application (Diamond, Platinum) EXHIBITOR'S SUITE application (Diamond, Platinum, Gold) EXHIBITORS FORUM application (Diamond, Platinum, Gold, Silver) ➔ Application Form 1	August 22 (Fri), 2025
Submission of LUNCH SPEAKER SESSIONS information (Diamond, Platinum) ➔ Application Form 2	August 22 (Fri), 2025
<ul style="list-style-type: none"> Exhibition space allocation Submission of optional items and rental furniture order form 	Early September, 2025
Invoice (sponsorship packages & other customized sponsorship streams)	End of August, 2025
Payment due date (sponsorship packages & other customized sponsorship streams)	September 30 (Tue), 2025
Submission of booth plan (raw space only)	October 30 (Thu), 2025
Submission of EXHIBITORS FORUM Information (Diamond, Platinum, Gold, Silver) ➔ Application Form 3	October 30 (Thu), 2025
Optional items /Lunch order deadline	November 28 (Fri), 2025
Optional items /Lunch payment deadline	December 31 (Wed), 2025
Booth setup	January 26 (Mon), 2026
Exhibition	January 27 (Tue) - 29 (Thu), 2026
Teardown	January 29 (Thu), 2026

Kindly refer to the respective links for each application form.

SPONSORSHIP REGISTRATION PROCESS

Registration

Companies wishing to support SCA/HPCAsia 2026 are asked to complete the Sponsorship Registration Form.

Registration Deadline

August 22 (Fri), 2025

Be Our Sponsor Today!



<https://sca-hpcasia2026.kyosan.cloud>

Sponsorship Registration and Confirmation

The Sponsorship Secretariat of SCA/HPCAsia 2026 will confirm the sponsor's commitment and issue an invoice upon receipt of the Sponsor and Exhibitor Reservation Form. Should multiple sponsors apply for the same sponsorship opportunity, priority may be given based on the date of receipt of the reservation form.

Payment and Cancellation

Payment

Specific directions for payment of sponsorship will be provided upon commitment, and will be accompanied by an invoice. All amounts due must be paid in Japanese Yen (JPY).

Cancellation and Withdrawal

A cancellation is only granted in exceptional circumstances. Sponsors must send a cancellation request to the Sponsorship Secretariat of SCA/HPCAsia 2026 by August 22. If a cancellation is granted, the sponsorship fee may be refunded.

Code of Ethics

This conference will be conducted in accordance with the ACM Code of Ethics and Professional Conduct, which can be accessed via the following link:

<https://www.acm.org/code-of-ethics>

Exhibition Space Allocation

SCA/HPCAsia 2026 reserves the right to allocate exhibition space at its discretion.

Secretariat

Sponsorship Secretariat of SCA/HPCAsia 2026

c/o Convention Linkage, Inc.

11F PIAS TOWER, 3-19-3 Toyosaki, Kita-ku, Osaka-city, Osaka 531-0072, Japan

E-mail: sponsor-sca_hpcasia_2026@c-linkage.co.jp

Tel: +81-6-6377-2188

EXHIBITOR MANUAL

Exhibition Schedule

Move-in and Booth setup	January 26 (Mon) 10:00AM-8:00PM for exhibitors who ordered raw space and an external booth builder. 2:00PM-8:00PM for exhibitors who ordered the basic booth.
Exhibition	January 27 (Tue) 9:30AM-5:00PM January 28 (Wed) 9:00AM-5:00PM January 29 (Thu) 9:00AM-3:30PM
Teardown and Move-out	January 29 (Thu) 3:30PM-8:00PM

Booth Design

Exhibitors are requested to choose one of the following two booth plans:

- 1) Raw space
- 2) Basic booth

1) Raw space (space only)

Exhibitors are responsible for their booth building, including the cost of construction work to set up power supply lines and for electricity use. Booth locations are indicated (marked) on the exhibition floor. All exhibitors choosing external booth builders (NOT ordering a basic booth via the Sponsorship Secretariat of SCA/HPCAsia 2026) must submit a detailed cosmetic and technical plan and obtain approval from the Sponsorship Secretariat of SCA/HPCAsia 2026. SCA/HPCAsia 2026 will not provide any introductions to external booth builders or contractors.

EXHIBITOR MANUAL

2) Basic booth (with the basic booth package)

Exhibitors choosing a basic booth will receive the basic booth package listed below. They can also choose from the optional items listed under 'Optional items'.

Platinum

(4m x 4m)

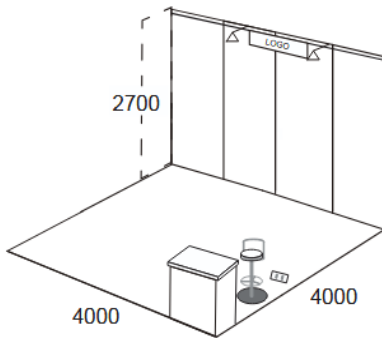

	Amount	Unit Price	Quantity	Total
•Basic booth package				
Back panel (W990mm x H2,700mm)	1	6,000	4	24,000
Reception counter (W990mm x D450mm x H900mm) & high chair	1	30,000	1	30,000
Set-up & removal	1	40,000	1	40,000
				94,000

The following items will be included in the basic booth package:
 Company signboard, Spotlight x 2,
 Single-phase 100V/300W outlet (2-pronged) x 1,
 Floor:punched carpet

•Optional items	Amount	Unit Price		
Side panel (W990mm x H2,700mm)	1	6,000	as requested	as requested
Table set (1 table & 4 chairs)	1	35,000		
A1 panel (printing only)	1	13,000		
A1 panel graphic (layout & printing)	1	27,000		
Side panel graphic (printing only)	1	40,000		
Side panel graphic (layout & printing)	1	70,000		
Reception counter graphic	1	20,000		

Gold

(2m x 4m)

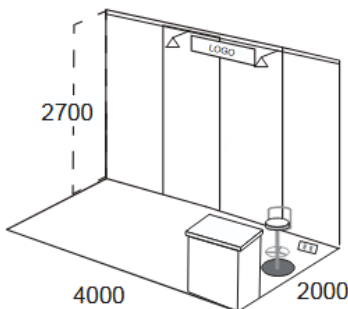

	Amount	Unit Price	Quantity	Total
•Basic booth package				
Back panel (W990mm x H2,700mm)	1	6,000	4	24,000
Reception counter (W990mm x D450mm x H900mm) & high chair	1	30,000	1	30,000
Set-up & removal	1	40,000	1	40,000
				94,000

The following items will be included in the basic booth package:
 Company signboard, Spotlight x 2,
 Single-phase 100V/300W outlet (2-pronged) x 1,
 Floor:punched carpet

•Optional items	Amount	Unit Price		
Side panel (W990mm x H2,700mm)	1	6,000	as requested	as requested
Table set (1 table & 4 chairs)	1	25,000		
A1 panel (printing only)	1	13,000		
A1 panel graphic (layout & printing)	1	27,000		
Side panel graphic (printing only)	1	40,000		
Side panel graphic (layout & printing)	1	70,000		
Reception counter graphic	1	20,000		

Note: Consumption tax is included in all prices.

EXHIBITOR MANUAL

Silver

(2m × 3m)

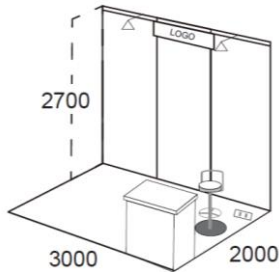

	Amount	Unit Price	Quantity	Total
•Basic booth package				
Back panel (W990mm x H2,700mm)	1	6,000	3	18,000
Reception counter (W990mm x D450mm x H900mm) & high chair	1	30,000	1	30,000
Set-up & removal	1	40,000	1	40,000
				88,000

The following items will be included in the basic booth package:
Company signboard, Spotlight x 2,
Single-phase 100V/300W outlet (2-pronged) x 1,
Floor:punched carpet

•Optional items	Amount	Unit Price		
Side panel (W990mm x H2,700mm)	1	6,000	as requested	as requested
A1 panel (printing only)	1	13,000		
A1 panel graphic (layout & printing)	1	27,000		
Side panel graphic (printing only)	1	40,000		
Side panel graphic (layout & printing)	1	70,000		
Reception counter graphic	1	40,000		

Bronze

(2m × 2m)

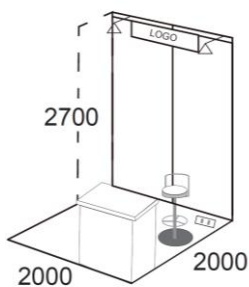

	Amount	Unit Price	Quantity	Total
•Basic booth package				
Back panel (W990mm x H2,700mm)	1	6,000	2	12,000
Reception counter (W990mm x D450mm x H900mm) & high chair	1	30,000	1	30,000
Set-up & removal	1	40,000	1	40,000
				82,000

The following items will be included in the basic booth package:
Company signboard, Spotlight x 2,
Single-phase 100V/300W outlet (2-pronged) x 1,
Floor:punched carpet

•Optional items	Amount	Unit Price		
Side panel (W990mm x H2,700mm)	1	6,000	as requested	as requested
A1 panel (printing only)	1	13,000		
A1 panel graphic (layout & printing)	1	27,000		
Side panel graphic (printing only)	1	40,000		
Side panel graphic (layout & printing)	1	70,000		
Reception counter graphic	1	40,000		

Start-up

(1m × 1m)

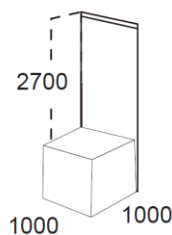

•Basic booth package
Back panel (W990mm x H2,700mm)
Display table

Note: Consumption tax is included in all prices.

Additional optional items beyond those listed above may also be available.
Please contact the SCA/HPCAsia 2026 Sponsorship Secretariat for more information.

SPONSOR and EXHIBITOR BENEFITS

Attendee Contact List (Diamond, Platinum, Gold)

Diamond, Platinum and Gold sponsors will receive the contact information of registered attendees who have agreed to share their data (name, company name, job title, email address, country) in compliance with the Japanese Personal Information Protection Act.

Complimentary Passes

Conference and Exhibition passes will be issued to participating companies based on sponsorship entitlements. At least one exhibitor must always be present at the booth during exhibition hours. Sponsors can allocate the passes included in their package to any member of staff or guest of their choice.

All participants attending SCA/HPCAsia 2026 on-site must be registered. Online registration will be available in early October. Upon arrival, each participant must check-in in person at the check-in desk to receive a badge. Access will not be granted without a badge.

Exhibition Space

Exhibitors are requested to choose one of the following two booth plans:

- 1) Raw space (space only)
- 2) Basic booth (with the basic booth package)

Please refer to the Exhibitor Manual for details.

Exhibitors Forum (Diamond, Platinum, Gold, Silver) – Onsite Speaking Opportunity

Diamond, Platinum, Gold and Silver sponsors are entitled to deliver 15-minute talk in the Exhibitors Forum. This session is open to all attendees. Sponsors wishing to give a talk in the Exhibitors Forum are requested to submit the application form on page 6 to the Sponsorship Secretariat of SCA/HPCAsia 2026 by the deadline.

Speakers at the Exhibitors Forum must register using one of the complimentary passes included in their sponsorship package or with a paid pass (either a conference or exhibition pass).

- Date: January 27 (Tue) - 29 (Thu), 2026
 - Venue: 3F Exhibition Hall
 - Exhibitor Forum hours: 1:30 PM - 5:30 PM (tentative)
 - Capacity: Theater-style with 30 seats and some high tables
 - Length of the talk: 15 minutes for each sponsor / 10-12 slots per day
- * Sponsors will be notified of their time slot and all other relevant information by the Sponsorship Secretariat of SCA/HPCAsia 2026.

SPONSOR and EXHIBITOR BENEFITS

Items included in the Exhibitors Forum

- Standard AV setup, including projection screen
- One podium and one laptop with a live screen feed
- Microphones (one podium microphone, one microphone for the moderator)
- Sound system
- Chairs and high tables for the audience

Submission Process

1. Application Form for Exhibitors Forum
2. Session information
 - Title of the talk
 - Speaker information (name, affiliation)
 - Session description

Note : Please refer to page 6 of the Sponsorship Registration Process for the deadline.

Exhibitors Suite (Diamond, Platinum, Gold)

Sponsors may apply for an Exhibitors Suite (full day). Diamond and Platinum sponsors will be given priority. The Sponsorship Secretariat of SCA/HPCAsia2026 will provide an application form to each sponsor individually in accordance with the registration order.

Logo Exposure

All SCA/HPCASia2026 sponsors and exhibitors will have the opportunity to display their logo on the official website and in general conference materials. Sponsors will be asked to submit their official logos.

Lunch Speaker Sessions (Diamond, Platinum)

Diamond and Platinum sponsors are entitled to host a 60-minute session during the lunch break. Sponsors wishing to hold a Lunch Speaker Session are requested to submit the application form on page 6 to the Sponsorship Secretariat of SCA/HPCAsia 2026 by the deadline.

Room Information

Date & Time	Date & Time	Available rooms	Capacity	Lunch Style
Type A	January 27 (Tue) - 29 (Thu), 2026 12:00 PM-1:00 PM (tentative)	3	Theater-style, 400 seats	Buffet / Bento box
Type B	January 27 (Tue) - 29 (Thu), 2026 12:00 PM-1:00 PM (tentative)	12	Theater-style, 170-190 seats	Bento box

SPONSOR and EXHIBITOR BENEFITS

- Sponsors are responsible for the program, including lunch arrangements.
- If the stage layout is changed to accommodate the activities such as panel discussions, sponsors are responsible for returning the room to its original configuration within their allocated time.
- Prior registration will be requested for the participants who wish to attend the session.

|Items included in the session

- Theater-style setup with a stage
- Standard AV setup, including a projection screen appropriate to the room size
- One podium and one presentation system (PC and monitor) with a live screen feed, mouse, slide advancer, and monitor at the moderator table
- Microphones (one podium microphone, one table microphone for the moderator table, and floor microphones for audience Q&A)
- Sound system and stage lighting

|Items NOT included in the session

- Cost of lunch arrangements
- Additional equipment

|Submission Process

1. Application Form for Lunch Speaker Session

2. Session information

- Title of the presentation
- Speaker information (name, affiliation and photo)
- Session description

3. Lunch Ordering Form

The number of pre-registered participants as of mid-November will be shared by the Sponsorship Secretariat of SCA/HPCAsia 2026. Please complete your order by the designated deadline. For the lunch ordering schedule, please refer to page 6.

Promotional Materials

One (1) corporate brochure (maximum size: A4) and one (1) corporate gift can be inserted into the conference bag. Sponsors wishing to insert promotional materials are required to ship them by the specified time and to the specified place.

GUIDELINES and POLICIES for EXHIBITION

Cancellation or Closure of Exhibition

The exhibition may be cancelled or closed at the discretion of the organizers if it becomes impossible or impractical to hold the event due to natural disasters or other force majeure circumstances. In such cases, the organizers shall not be liable for any loss or damage incurred by the exhibitor, and sponsorship fees may not be refunded.

Demonstrations

Exhibitor demonstrations must not interfere with normal traffic flow or infringe on neighboring exhibits. Demonstrations are not permitted outside the exhibitor's assigned space.

Facility Regulations

Exhibitors are required to comply with all facility regulations regarding the design, installation, operation, and dismantling of their exhibit stands. A complete description of electrical, fire, labor, and property regulations will be provided in the Exhibitor Manual, which will be updated in early September.

Please also review the Osaka International Convention Center (OICC) facility information, safety measures and other guidance.

[OICC Usage Guide](#)

Food and Beverage Distribution

Exhibitors wishing to serve or distribute any food or beverages from their assigned exhibit space must notify the venue and, in principle, use the designated catering company. Additional fees will apply to those bringing in outside catering. Further information will be provided in the Exhibitor Manual, to be distributed in early September.

Liability

The exhibitor shall be fully responsible for any and all damage to property owned by the venue, its owners, or managers, resulting from any act or omission by the exhibitor. The exhibitor agrees to defend, indemnify, and hold harmless SCA/HPCAsia 2026, along with its owners, managers, officers, directors, agents, employees, subsidiaries, and affiliates, from any claims, damages, or charges arising from the exhibitor's use of the property.

This liability includes, but is not limited to, all losses, costs, damages, or expenses resulting from any accident, bodily injury, or other incident involving any person (including the exhibitor, their agents, employees, or business invitees) that occurs as a result of the exhibitor's occupancy or use of the exhibition premises, the venue, or any part thereof.

In addition, the exhibitor should acknowledge that SCA/HPCAsia 2026, the venue, and all related service providers do not insure the exhibitor's property. It is the sole responsibility of the exhibitor to obtain appropriate insurance, including business interruption and property damage coverage, for any potential loss.

GUIDELINES and POLICIES for EXHIBITION

Merchandise Sales

Selling merchandise is prohibited at SCA/HPCAsia 2026.

No Smoking

Smoking is prohibited in all public areas of the venue.

Promotional Items

A promotional item approval form which will be included in the Exhibitor Manual must be submitted to the Sponsorship Secretariat of SCA/HPCAsia 2026.

Exhibitors wishing to use the official conference logo on their promotional materials must submit a sample, photo, or written description of each item to SCA/HPCAsia 2026 for prior approval.

The conference official logo is available from [here](#)

Relocation

SCA/HPCAsia 2026 reserves the right to relocate exhibitors. If it becomes necessary to relocate an exhibitor after a specific space has been assigned, SCA/HPCAsia will notify the exhibitor. Every effort will be made to reassign the exhibitor to a comparable space.

Restriction of Exhibits

SCA/HPCAsia 2026 reserves the right to:

- (a) reject any application to exhibit at the SCA/HPCAsia 2026 for any reason;
- (b) prohibit, restrict, or require modification of any exhibit for any reason; and
- (c) evict or bar any exhibitor whose exhibit, materials, or conduct is deemed objectionable for any reason.

Violation of any regulations by the exhibitor, their employees, or agents will result in the forfeiture of the right to occupy the space, and all fees paid will be retained by SCA/HPCAsia 2026.

Upon evidence of such a violation, SCA/HPCAsia 2026 may enter and take possession of the space occupied by the exhibitor, removing all persons and goods at the exhibitor's risk. The exhibitor shall be responsible for any expenses or damages incurred by SCA/HPCAsia 2026 as a result.